



Standard Guide for Marine Vessel Structural Inspection Considerations¹

This standard is issued under the fixed designation F 1754; the number immediately following the designation indicates the year of original adoption or, in the case of revision, the year of last revision. A number in parentheses indicates the year of last reapproval. A superscript epsilon (ϵ) indicates an editorial change since the last revision or reapproval.

1. Scope

1.1 This guide covers information to develop and implement a marine vessel inspection process. It is intended to provide considerations for persons interested in planning, organizing, and implementing a structural survey plan for a marine vessel, especially during the design phase of the vessel. It is intended to be used in conjunction with any other required inspection or survey requirements but can form the basis for such planning in the absence of other such applicable requirements.

1.2 This guide provides owners, operators, shipyards, and designers with a plan for developing a detailed inspection process that covers all stages of the operating life of a marine vessel, including the design, construction, and in-service periods. This plan may be developed and used in concert with classification society and flag state surveys and inspections.

1.3 This guide also provides the basis for development of a recommended corrective action plan for typical structural deficiencies or deviations, or both.

1.4 *This standard does not purport to address all of the safety concerns, if any, associated with its use. It is the responsibility of the user of this standard to establish appropriate safety and health practices and determine the applicability of regulatory limitations prior to use.*

1.5 All portions of this guide may not be applicable to all vessels or shipyards since many yard-specific standards to ensure contracted level of quality are in existence.

2. Referenced Documents

2.1 ASTM Standards:

F 1053/F 1053M [Guide for Steel Hull Construction Tolerances²](#)

3. Terminology

3.1 Definitions of Terms Specific to This Standard:

¹ This guide is under the jurisdiction of ASTM Committee F25 on Ships and Marine Technology and is the direct responsibility of Subcommittee F25.01 on Structures.

Current edition approved Nov. 1, 2008. Published November 2008. Originally approved in 1996. Last previous edition approved in 2004 as F 1754 - 97(2004).

² Withdrawn.

3.1.1 *blind spots, n*—areas of a vessel's structure that cannot be visibly or electronically inspected for failure.

3.1.2 *large tanks, n*—tanks of such dimension as to have uninspectable heights greater than 10 m.

3.1.3 *telltale areas, n*—areas of a ship's structure identified by analyses and investigations during design development as being subject to higher stresses or more susceptible to fatigue than others, even though the higher stresses are still within allowable limits. Also, areas identified after the vessel is placed in service that continue to experience active or recurring cracking in the watertight envelope or that affect the structural integrity of the vessel.

4. Introduction

4.1 As stated earlier, the intent of this guide is to assist in the preparation of an inspection plan for a marine vessel during its design, construction, and in-service stages and to plan for inspection during the design. This guide should be used in the preparation of a specific inspection program for the construction of a specific marine vessel. It is not intended to set any stringent requirements for the structural inspections of any particular vessel. The suggestions for various inspection considerations in this guide are presented for the purpose of making available for review and use a broad set of guidelines.

4.2 This guide is applicable to all commercial and pleasure marine vessels. Although the references generally apply to steel and aluminum welded hulls, the overall aspects may be applied to any material or type of construction.

4.3 At any point of its construction or service life, the vessel may require classification society or flag state regulatory inspections, or both, as well as shipowner's surveys. The surveys, depending on occasion, should consider the general condition of the vessel, provide a detailed condition assessment, obtain data to determine corrosion rate and damage, or obtain information for repair specification development, or a combination thereof. The inspection plan should take into account all of these types of information in its development. On occasions, the surveys also should obtain data on rate of coating breakdown.

4.4 Because of severe loadings, excessive wastage, poor structural design, improper use of materials, excessive fatigue cycling, and so forth, failure may occur at any structure

component at some stress value that is much less than the theoretically allowable limit. Therefore, detection of such conditions by careful analysis and by sufficient inspection throughout the entire process is consequently crucial for the prevention of failure. This guide describes generically the extent of and the procedures for inspections to be performed at each stage of a marine vessel's life. Minor and major imperfections can be detected early in the construction process. Therefore, structural integrity can be maintained with periodic in-service inspections and appropriate and timely corrective measures to prevent any accumulation of defects or costly rework.

4.5 From construction and early service life inspections, a structural history of the vessel can be prepared forming the basis on which future in-service inspection results can be evaluated.

5. Inspection Considerations During Design Stages

5.1 To ensure the marine vessel's structural integrity, the designers should consider the following inspection-related requirements during the design stages:

5.1.1 *Inspectability of a Marine Vessel's Structure During Construction and In-Service:*

5.1.1.1 *Background*—During the life of any marine vessel, several inspections are conducted on the structure. These consist of two types that directly reflect their purpose, convenience and regulatory. In conducting either one, certain locations require access that are not readily accessible without climbing the structure or obtaining assistance from mechanical devices. When an inspection requires the use of mechanical means to access the structure, several options are available. They include anything from a simple platform elevated by a hoist connected at the overhead to a sophisticated ROV (Remote Operated Vehicle) that permits the inspector to remain outside the tank altogether. An issue that must be recognized is the degree of inspection. In other words, how close does one want to be to the structure, how accurate does the inspection need to be, and how long does one have to conduct the inspection. The definition of the "degree of inspection" has a direct bearing on the conclusions drawn from information presented herein.

5.1.1.2 For the purposes of this guide, the following assumptions are made relative to the degree of inspection:

5.1.1.3 The inspected structure must be in direct line of sight.

5.1.1.4 The inspected structure must be in clear and distinct view, taken as a distance of not more than 1.5 m (5 ft) from one's eyes.

5.1.1.5 The structure is to be inspected to a degree that would reveal almost all fractures that have a length of 50 mm (2 in.) or more. This depends significantly on the cleanliness, lighting level, stress, and so forth, of the structure.

5.1.1.6 The inspection shall be conducted in a continuous manner such that the shortest amount of time is taken for it.

5.1.1.7 For the purposes of inspection, the structure should be broken down into discrete zones, such as those depicted in Fig. 1. Where the structure differs from that depicted in Fig. 1, an appropriate scheme of identifying zones for inspection should be adopted.

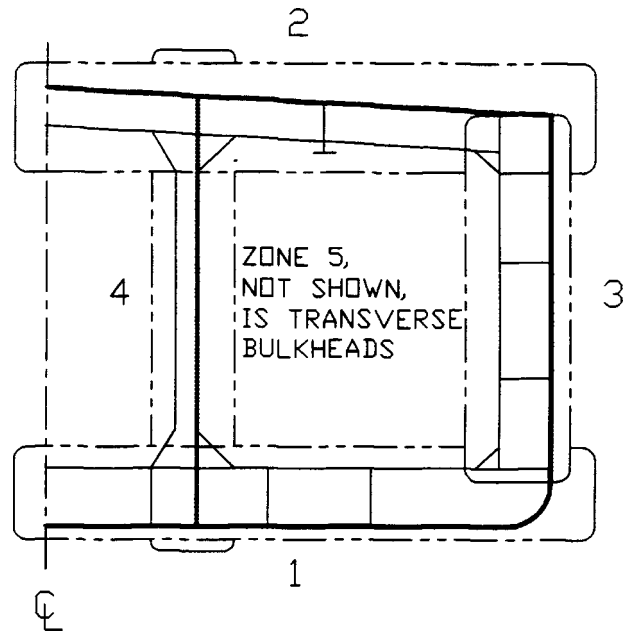

FIG. 1 Hull Girder Structure Areas Designated by Zones

(1) *Zone 1*—The bottom and inner bottom shell structure including the turn of bilge and any structure attached to them.

(2) *Zone 2*—The deckhead structure, from ship's side to ship's side, including the stiffening attached to it.

(3) *Zone 3*—The side shell structure, including the side bulkhead structure for double hull vessels, including the stiffening attached to it.

(4) *Zone 4*—The longitudinal bulkhead structures that include the centerline and side longitudinal bulkheads, except a side bulkhead of a double hull structure.

(5) *Zone 5*—The transverse bulkhead structure, fore and aft sides, extending from the bottom shell to the deckhead.

5.1.1.8 *Means of Access SOLAS Regulation II-1/3.6*—SOLAS requires access to and within spaces in, and forward of, the cargo area of oil tankers of 500 gross tonnage and over and for bulk carriers of 20,000 gross tonnage and over on or after 1 January 2006. These types of ships will have an approved Ship Structure Access Manual that should be referenced when carrying out overall, close up inspections and thickness measurements.

5.1.2 *Access Methods:*

5.1.2.1 *Fixed Staging*—This method consists of poles, fittings, planks, and ladders that create a tower or walkway. This is the only method that permits access to all structural areas of a vessel. To achieve this coverage, however, it is very expensive and time consuming. A simple description of the method could be compared to an erector set. It is a straightforward method to which most people can relate. It may be a method that more people feel comfortable using than some. Accessing a deckhead structure that is 20 m (66 ft) or so above the bottom, however, is not a place for anybody with a fear of heights. This method has been a standard access method for conducting inspections and repairs to vessels for many years. The components are better designed and lighter in weight than ten or more years ago. Therefore, it is more easily constructed today.

5.1.2.2 Portable Staging—This method consists of a platform of sufficient size to carry at least one person. It also includes a winch that is attached to the platform. The wire on the winch is connected to the underdeck structure so that the platform raises towards the wire's connection point at the underdeck. The size of the platform varies. Some are sized to lift only one person while others are sized to lift up to four or five persons. In fact, some platforms are similar to those used by window washers—lightweight and breakdown for portability. For industrial applications, the staging is built more rugged than typically used for window washers, such that the design load is higher. Persons on the staging should have individual safety harnesses attached to them. The Occupational Safety and Health Administration (OSHA) has become more active in verifying contractors perform their work in a safe manner. One high-risk aspect of using this staging is attaching the lifting wires to the overhead. This normally is accomplished by a person walking the deckhead. This person uses a set of stirrups each attached to one end of a short length of wire with some type of hook at the opposite end. The hooks fasten into the deckhead structure, then a person proceeds to walk across the deckhead while moving the stirrups and connecting the platform's lifting wires to the deckhead. OSHA has become more aware of this activity due to fatalities. They now require these persons to wear safety harnesses connected to lifelines. An alternate method of attaching the lifting wires to the overhead, but not normally used, is by drilling holes into the deck and passing wires through them. The wire end is then secured to provide a holding point. The problem is that drilling holes into a deck is not a desired situation. It can become a source of future fracture problems if not properly done and might be located in an area of high stress.

5.1.2.3 Rafting—This is a straightforward system and may be the easiest to understand. It consists simply of rowing around in a rubber raft while the water level in the tank is changed in height. This method has been used for many years, not only for inspection reasons, but also for access to upper regions of a tank by the vessel's crew for conducting repairs. In fact, there are various objects that can be used to provide buoyancy when access to high areas in a tank is needed and a rubber raft is not available. For structural inspections, normally two persons occupy a raft; this enhances the raft's maneuverability and the inspection. All areas of the structure can be accessed easily from the level of the liquid. Vessels with deep transverse structures, however, prohibit safely accessing the deckhead structure. If the water rises, it traps the raft's occupants between the structure and water level without a safe exit from the tank. This applies to any tank with a deckhead structure to some degree. An important aspect of this method relating to the thoroughness of an inspection is the rate of water level change. If the intervals are too great, such as 5 m (16.5 ft) or more, only those areas immediately above the water level are really surveyed close-up. This method can be implemented to inspect the structure continuously while changing the water level. The rate of level change can be controlled to permit sighting nearly 100 % of the accessible structure. Additional

information about rafting may be found in IACS Recommendation 39, "Recommendation for safe use of rafts or boats for survey."

5.1.2.4 Climbing—This method often complements one of the other methods mentioned in the preceding sections. It varies from climbing the structure a short distance to see a particular location better, to climbing the height of the tank with the aid of a safety harness. The latter, although demonstrated, is not typically used. There are hazards when climbing any height; the higher one goes, the greater the risk of severe injury if one falls. Prudent judgment, therefore, is necessary to prevent accidents. This includes a decision to not climb to any height if the circumstances so indicate, for example, slippery conditions, physical problems, and so forth.

5.1.2.5 Other—The inspection methods here are not considered to be primary methods but rather ones that can support and enhance one or more of the methods previously described. They serve a specific purpose.

5.1.2.6 Ziggy—This mechanical device consists of a mechanism positioned above the deck that raises and lowers, and rotates from side to side, with a steel column constructed of short, rectangular tubes. The tubes are lowered through a butterworth hole to the bottom. A horizontal beam is attached to the bottom end of the column, and a single-person basket is attached to the other end of the beam. As the column is raised or lowered, the person in the basket can extend oneself to a distance between 3 and 9 m (10 and 30 ft) from the vertical column. This device permits one to inspect the side and underdeck structure without building a tower of staging, climbing the side shell, or filling the tank with water to the underdeck. It can be operated from the basket or from the deck positions.

5.1.2.7 Remote Operating Vehicle (ROV)—An ROV is similar to a miniature undersea, unmanned vehicle. This method also requires filling the tank with water. Unlike the rafting method, however, it is important to fill the tank as close to 100 % as possible. The ROV typically is sphere-like and has small, external propellers running inside ducts for maneuvering. They all include a camera. Some models are capable of doing additional operations other than viewing the tank internals, such as thickness gaging, cleaning off the surface, and varying the light intensity. An operator controls the ROV outside the tank at a control console. There is a monitor alongside to follow the maneuvers and to view the structure. A video tape of the whole inspection or parts thereof can be made. The communication link between the control panel and ROV is by cables connecting the two. It is important, therefore, to understand the compartment size and extent of inspection expected by the unit. The operator must understand the tank space where the ROV is operating. A knowledge of the internals, protruding obstacles, pipelines, and tank boundaries, therefore, is necessary to prevent the unit from becoming tangled in them.

5.1.2.8 Maricam—This unit could be considered a hybrid of the ROV and Ziggy methods. It consists of a high-resolution video camera mounted on a vertical column extended into the tank space from the deck. It too is remotely operated by two persons on deck who control the camera's movement, the light